

**Model** TURSP2T2.9G3.3G-40WA

## Absorption, Broadband PIN Switch 2.9-3.3 GHz, SP2T, N Female

**Feature:**

- Ultra Wide Band: 2.9-3.3 GHz
- Low Insertion Loss: 1.2 dB Max
- Power Handling : 40 W
- High Isolation
- Switch Type: Absorption

**电气特性 Electrical** :

参数 Parameter	Min	Typ	Max	单位 Units
频率范围 Frequency range	2.9-3.3			GHz
插损 Insertion Loss			1.2	dB
隔离 Isolation	40			dB
切换速度 Switch Speed			800	ns
输入驻波 Input VSWR			1.4	:1
输出驻波 Output VSWR			1.4	:1
耐功率 Power Handling			40	W
偏置电压 Bias Voltage	+5V/-12V			V
电流 Supply Current	200mA/50mA			mA
控制电平 Control Logic TTL	1:+3.5-+5V 0:0-+0.8V			V DC
阻抗 Impedance	50			Ohms

**机械特性 Mechanical** :

参数 Parameter	指标 Value	单位 Units
输入输出接口 Input /Output Connector	N Female/N Female	
直流控制接口 Control Bias	Solder Pin	
尺寸 Size	50*30*21	mm
重量 Weight	/	g

**绝对最大值 Absolute Maximum Ratings:**

参数 Parameter	指标 Value
供电偏置电压 Supply Bias Voltage	+5V
输入功率 RF Input Power	46.2 dBm
ESD灵敏度 ESD sensitivity (HBm)	Class 0, passed 150V

## 外形尺寸 Outline Drawing:

Unit: mm(Inches)

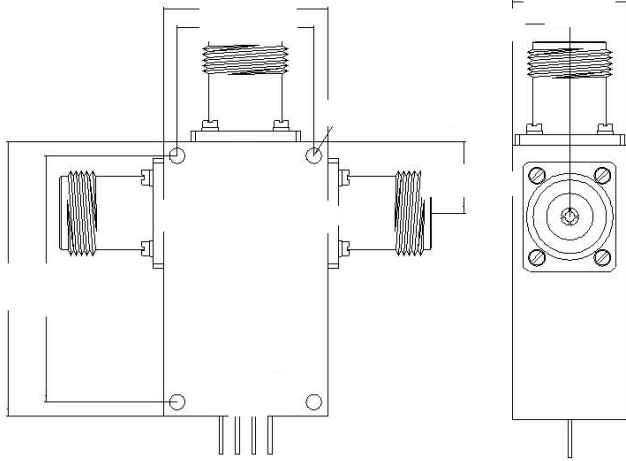

真值表 Truth Table

TTL Control Input	Signal Path State
E	
0	J0-J1
1	J0-J2



## 温度环境 Environmental Conditions:

参数 Parameter	Min	Typ	Max	单位 Units
操作温度 Operating Temperature	-40		+85	°C
存储温度 Non-operating Temperature	-55		+125	°C
相对湿度 Relative humidity		95		%
海拔 Altitude	50,000			feet
震动 Shock / Vibration(MIL-STD-810F)	25g rms (15 degree 2KHz) endurance, 1 hour per axis			
冲击 Shock(non operating)	20G for 11msc half sin wave,3 axis both directions			

## 订货信息 Ordering Information: