

TURVE-7511010 frequency extenders are a dedicated Test & Measurement solution for extending the range of your Vector Network Analyzer (VNA) to 75-110 GHz.

Features:

- Ultra Wide Band: 75-110 GHz
- Port Output Power (No Attenuation): 10 dBm Typ
- Dynamic Range @ 10 Hz BW: 110dB Typ
- Unconditional stability

Applications:

- VNA Frequency Extension
- Antenna measurements
- Material characterisation

电气特性 Electrical Characteristics:

参数 Parameter	Min	Typ	Max	单位 Units
频率范围 Frequency range	75		110	GHz
测试端口输出功率 Test Port Output Power		10		dBm
测试端口输入功率 Test Port Input Power (Damage)			20	dBm
输出功率衰减 Output Power Attenuation (Option:Variable attenuators)	0		30	dB
动态范围 Dynamic Range @ 10Hz BW	100	110		dB
方向性 Directivity		30		dB
射频输入频率 RF Input Frequency	11.16		18.33	GHz
射频输入功率 RF Input Power	3	5	7	dBm
RF倍频次数 RF Multiplication Factor		6		
本振输入频率 LO Input Frequency	11.16		18.33	GHz
本振输入功率 LO Input Power	3	5	7	dBm
LO倍频次数 LO Multiplication Factor		6		
中频频率范围 IF Frequency Range	1		1000	MHz
幅度稳定度 Amplitude stability @300 Hz BW		±0.1		dB

机械特性 Mechanical Specifications:

参数 Parameter	指标 Value
RF/LO输入接口 RF/LO Input Connector	SMA Female
MEA/REF IF输出接口 MEA/REF IF Output Connector	SMA Female
测试端口 Test Port Connector	WR-10/UG-387/U
供电 Power Supply Pin	FGG 0B 4 Core
尺寸 Size	210*81*46.2mm

绝对最大值 Absolute Maximum Ratings :

描述 Description	参数 Parameter	单位 Units
测试端输入功率 Test Port Input Power	+20	dBm
RF/LO端损坏等级 RF/LO Port Damage Level	+10	dBm
供电偏置 Supply Bias Voltage	+240 V AC	
ESD灵敏度 ESD sensitivity (HBm)	Class 0, passed 150V	

外形图 Outline Drawing: Unit:mm

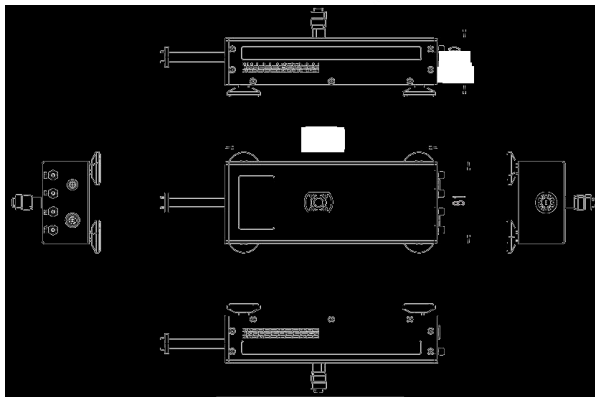

TURVE-7511010 A

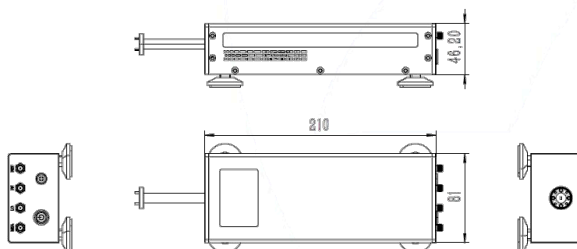

原理框图 Block Diagrams:

环境和物理特性 Environmental And Physical

描述 Description	参数 Parameter	单位 Units
操作温度 Operating Temperature	0 To +45	°C
存储温度 Storage Temperature	-55 to +125	°C
材质 Material	Al	
表面处理 Finish	Gray spray paint	

订货信息 Ordering Information:

标准型号 Part Number	描述 Description	版本号 Revision
TURVE-7511010	W-band VNA Frequency Extender, 75-110 GHz, Output Power:10 dBm typ., Dynamic Range:110 dB typ.,Magnitude Stability @ 300 Hz BW:±0.1dB,Phase Stability @ 300 Hz BW:±2.5°	Rev.1.1
TURVE-7511010 A	W-band VNA Frequency Extender, 75-110 GHz, Output Power:10 dBm typ., Dynamic Range:110 dB typ.,Magnitude Stability @ 300 Hz BW:±0.1dB,Phase Stability @ 300 Hz BW:±2.5°,with Micrometer driven variable attenuators	Rev.1.1

随货配件 Components Included:

标准型号 Part Number	描述 Description	数量 Quantity
S1-SMAMSMAM-1.2m	COAXIAL CABLE ASSEMBLY	4 PCS

典型曲线 Typical Performance Data:

Output Power vs Frequency

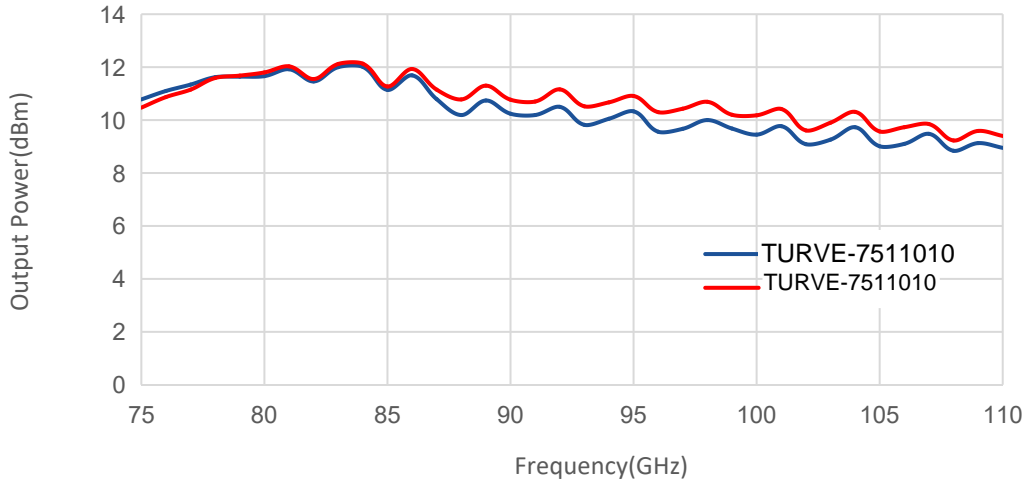

Dynamic Range vs Frequency

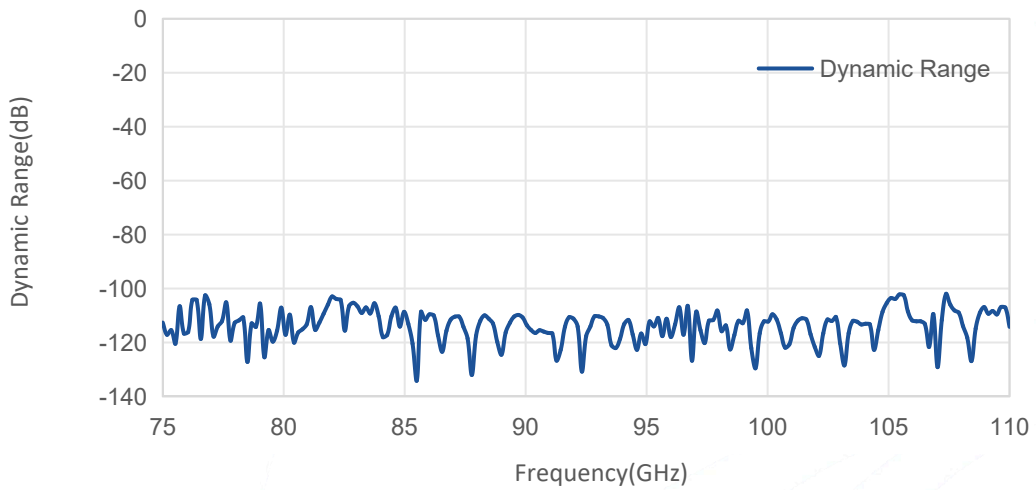

Stability@1h vs Frequency

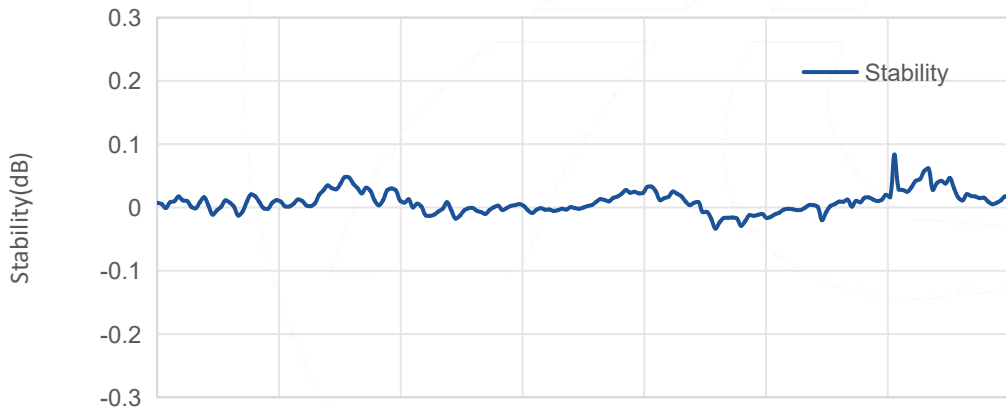

典型曲线 Typical Performance Data:

Effective Directionality vs Frequency

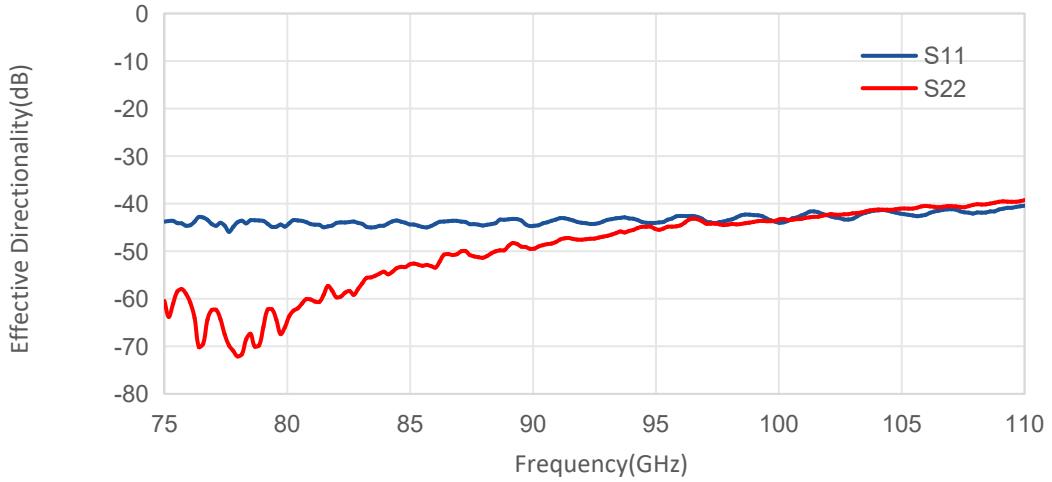

Payload Matching vs Frequency

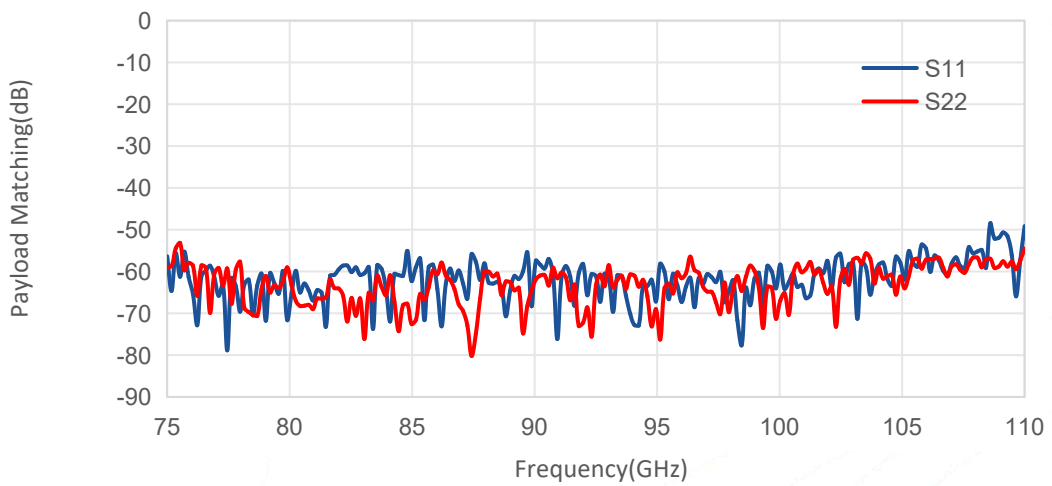

ReflectionTracking vs Frequency

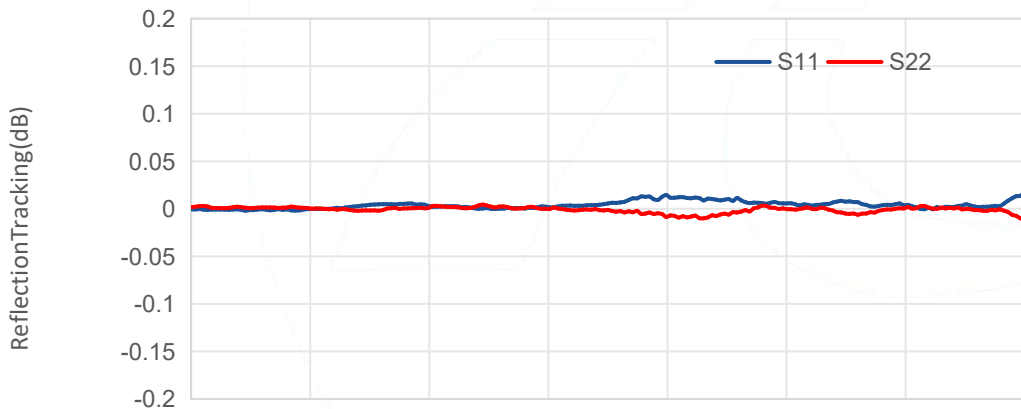

典型曲线 Typical Performance Data:

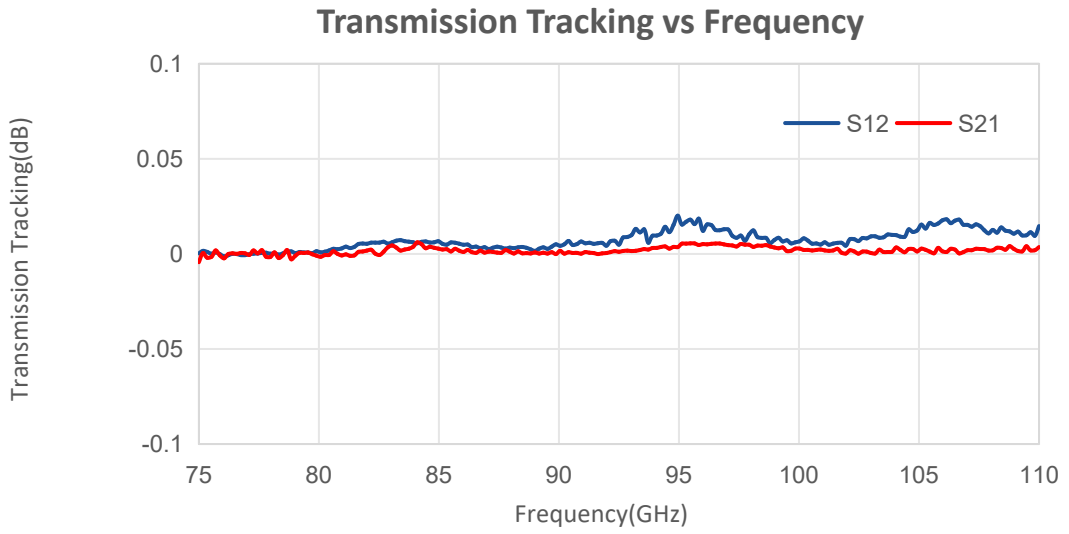

Note: Above data is for ref only, actual data may vary from unit to unit depending on operating environment and other factors like material lots etc.