

Model TURVP1G2G-36012

Voltage Controlled Phase Shifter 1-2GHz

Feature:

- Frequency Range: 1-2GHz
- High Phase Shift Accuracy
- High Phase Shift Range
- Single Positive Control Voltage

电气特性 Electrical :

参数Parameter	Min	Typ	Max	单位Units
频率范围 Frequency range	1-2			GHz
移相范围 Phase Range	360			°
插损 Insertion Loss		4.6	5	dB
输入IP3 Input IP3		25		dBm
输入驻波 Input VSWR		2.1	2.5	:1
输出驻波 Output VSWR		2.1	2.5	:1
控制电压 Control Voltage Range	0	12		V
控制电流 Control Current		20		mA
相位平坦度 Phase Flatness			±15	°
输入功率 Input Power			25	dBm
阻抗 Impedance	50			Ohms

机械特性 Mechanical :

参数Parameter	指标 Value	单位Units
输入/输出接口 Input /Output Connector	SMA Female/SMA Female	
尺寸 Size	20*14*9.5	mm
重量 Weight	20	g

绝对最大值 Absolute Maximum Ratings:

参数Parameter	指标 Value
控制电压 Control Voltage Range	+15V
耐受功率 RF Input Power No damage	+25 dBm
ESD灵敏度 ESD sensitivity (HBm)	Class 0, passed 150V

外形尺寸 Outline Drawing:

Unit: mm

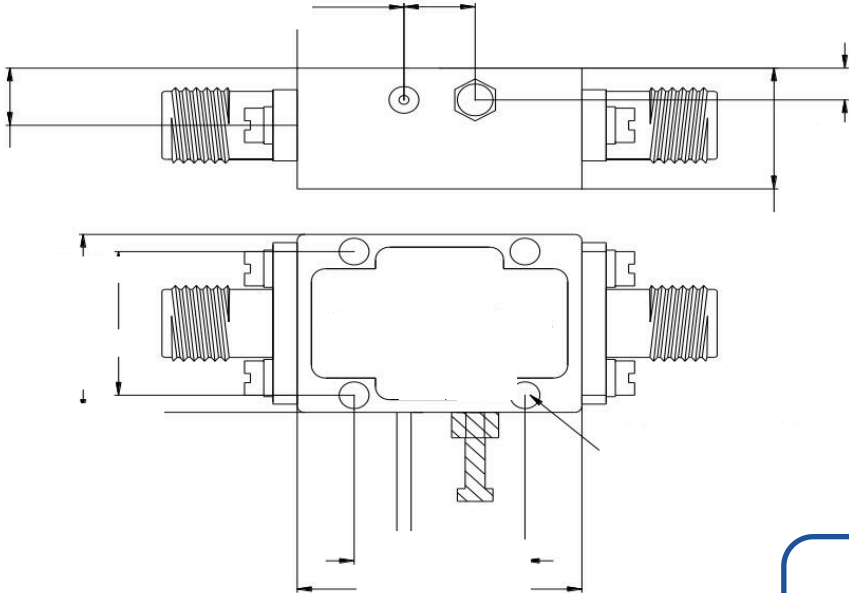

温度环境 Environmental Conditions:

参数Parameter	Min	Typ	Max	单位Units
操作温度 Operating Temperature	-40		+85	°C
存储温度 Non-operating Temperature	-50		+105	°C
相对湿度 Relative humidity		95		%
海拔 Altitude	50,000			feet
震动 Shock / Vibration(MIL-STD-810F)	25g rms (15 degree 2KHz) endurance, 1 hour per axis			
冲击 Shock(non operating)	20g for 11msc half sin wave,3 axis both directions			

订货信息 Ordering Information:

标准型号 Part Number	描述 Description	版本号Revision
TURVP1G2G-36012	Voltage Controlled Phase Shifter ,1-2GHz,SMA	Rev.1.1

典型曲线 Typical Performance Data:

0V:

Input VSWR vs Frequency

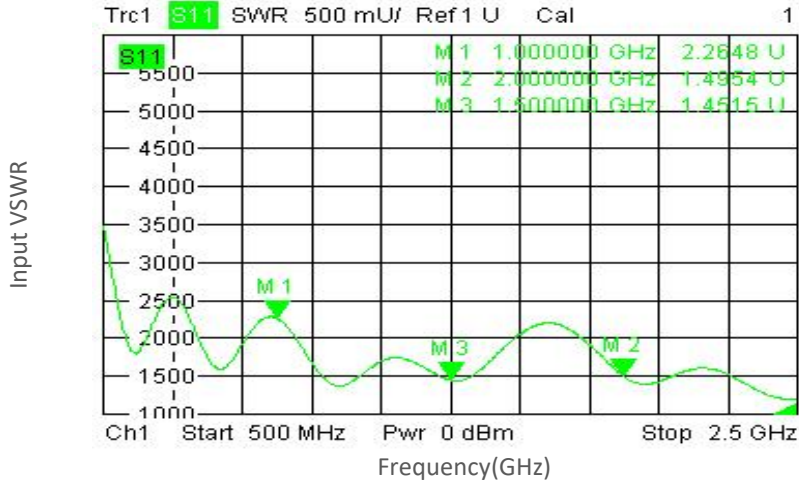

Output VSWR vs Frequency

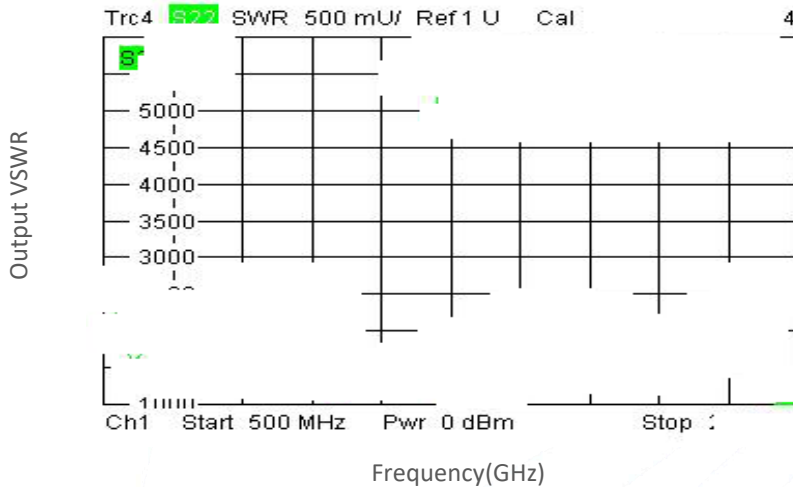

Phase vs Frequency

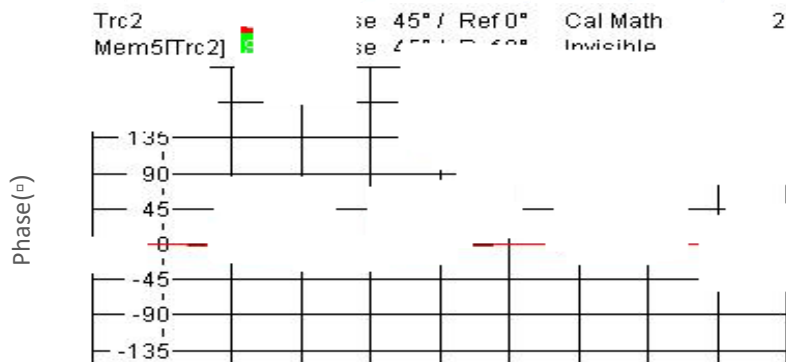

典型曲线 Typical Performance Data:

0V:

Insertion Loss vs Frequency

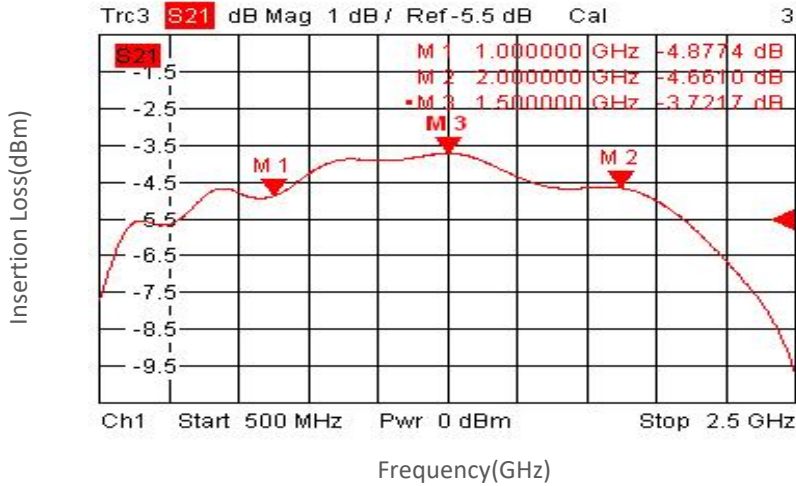

0.5V:

Input VSWR vs Frequency

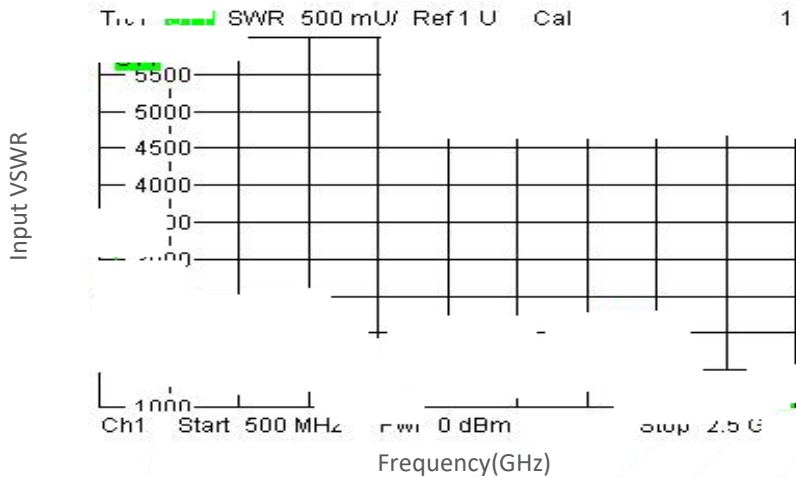

Output VSWR vs Frequency

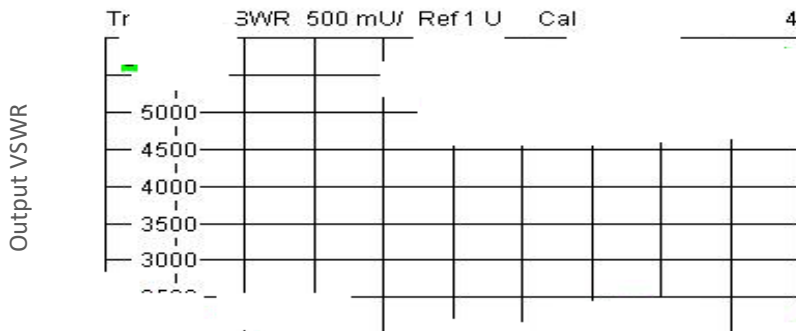

典型曲线 Typical Performance Data:

0.5V:

Phase vs Frequency

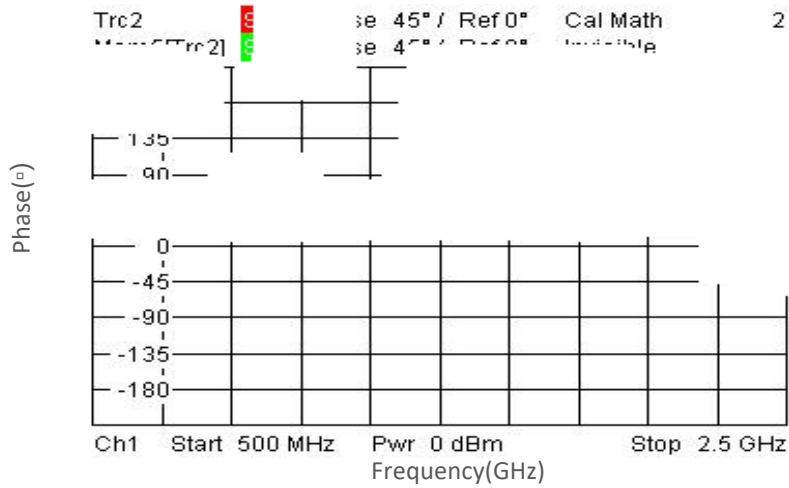

Insertion Loss vs Frequency

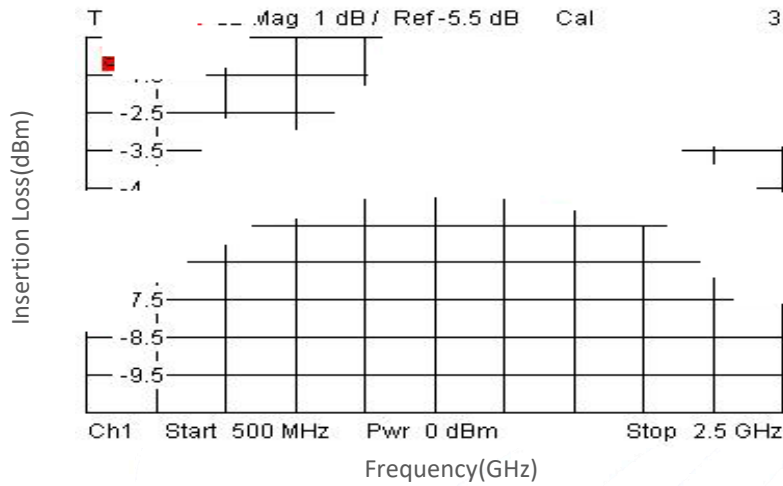

1.2V:

Input VSWR vs Frequency

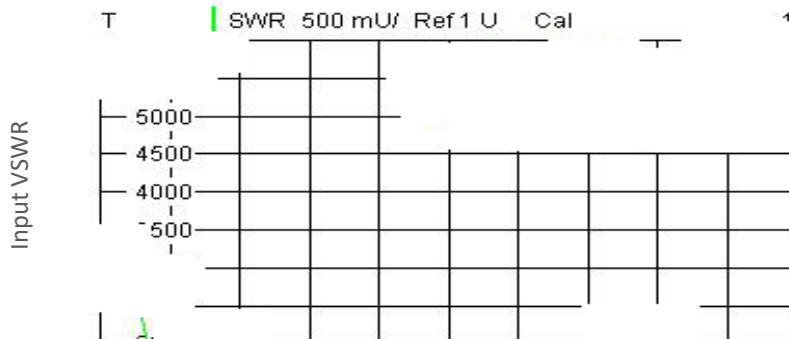

典型曲线 Typical Performance Data:

1.2V:

Output VSWR vs Frequency

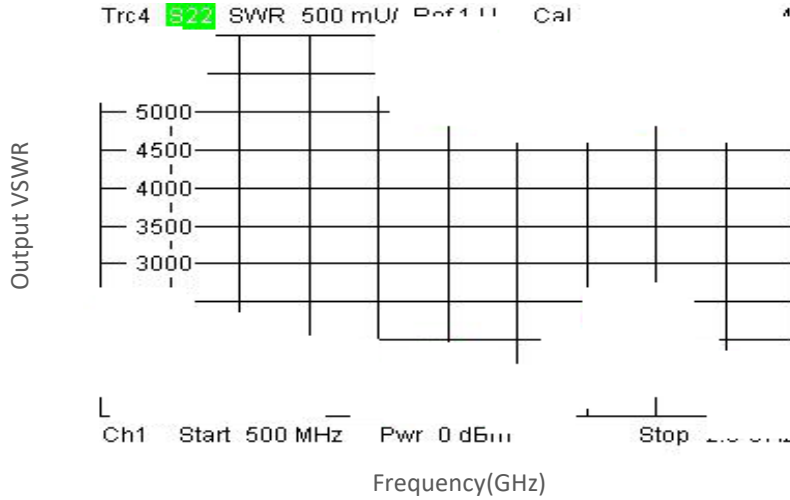

Phase vs Frequency

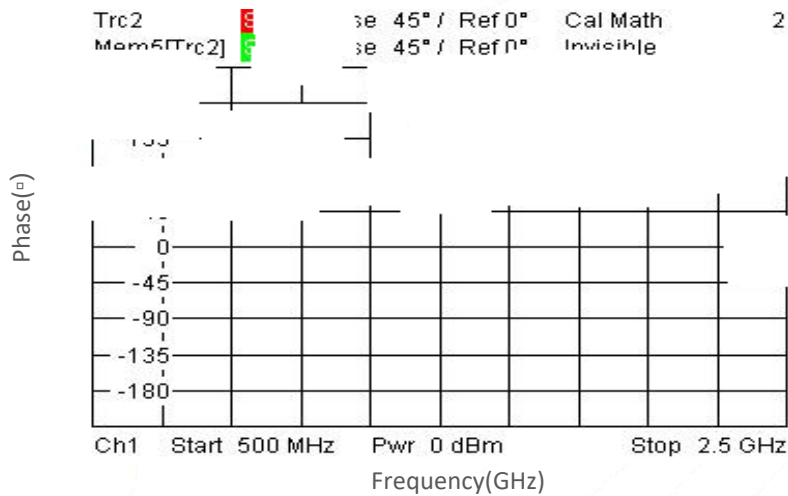

Insertion Loss vs Frequency

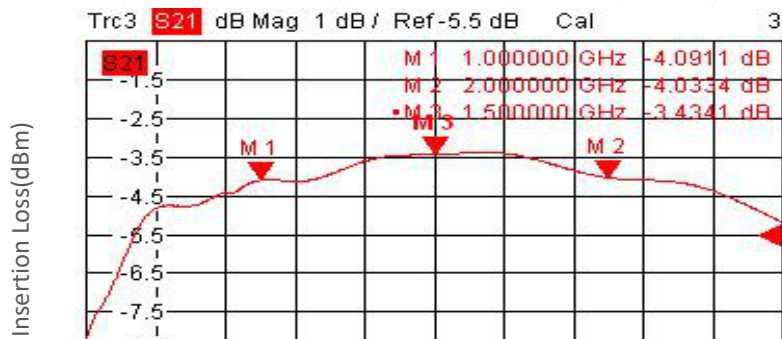

典型曲线 Typical Performance Data:

2.2V:

Input VSWR vs Frequency

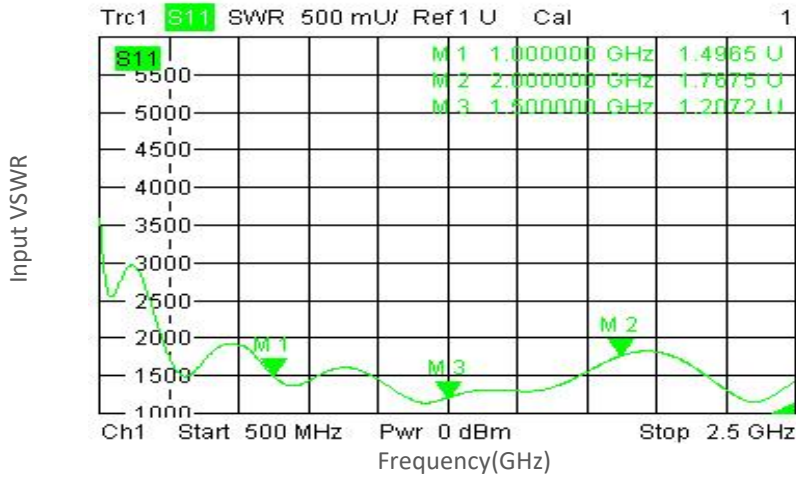

Output VSWR vs Frequency

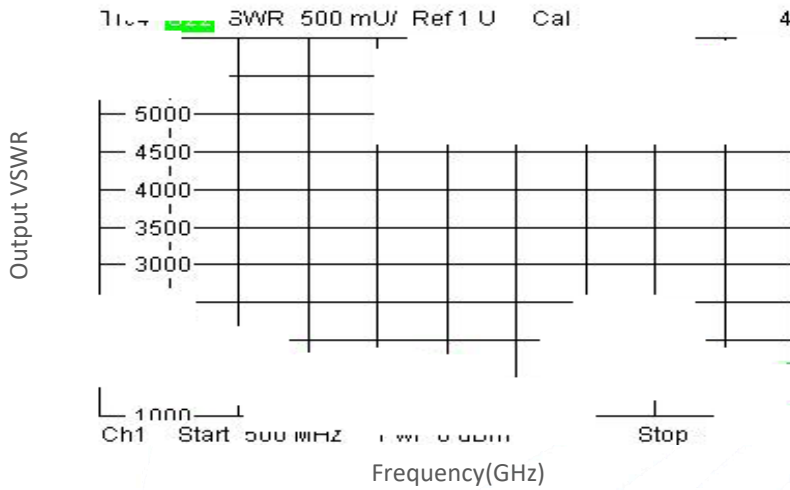

Phase vs Frequency

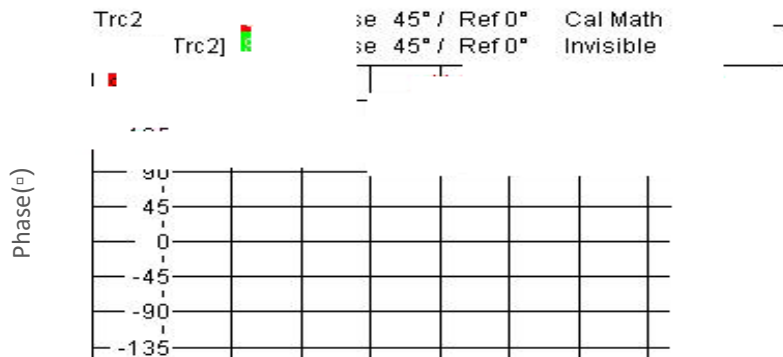

典型曲线 Typical Performance Data:

2.2V:

Insertion Loss vs Frequency

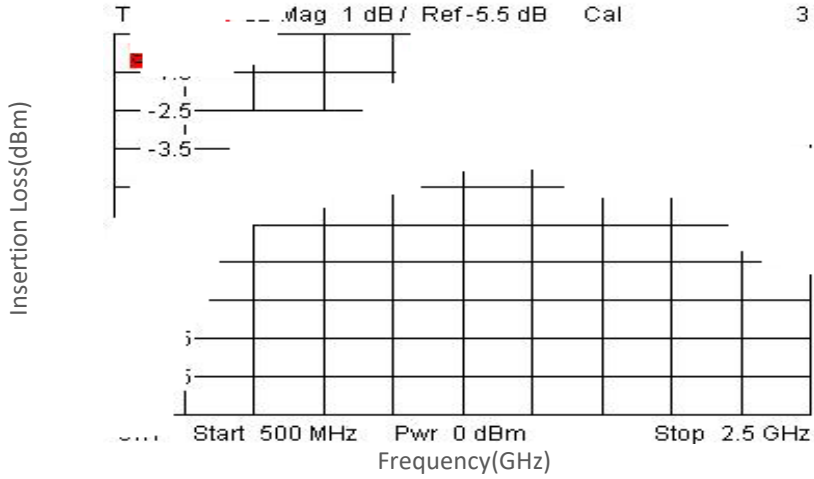

3.3V:

Input VSWR vs Frequency

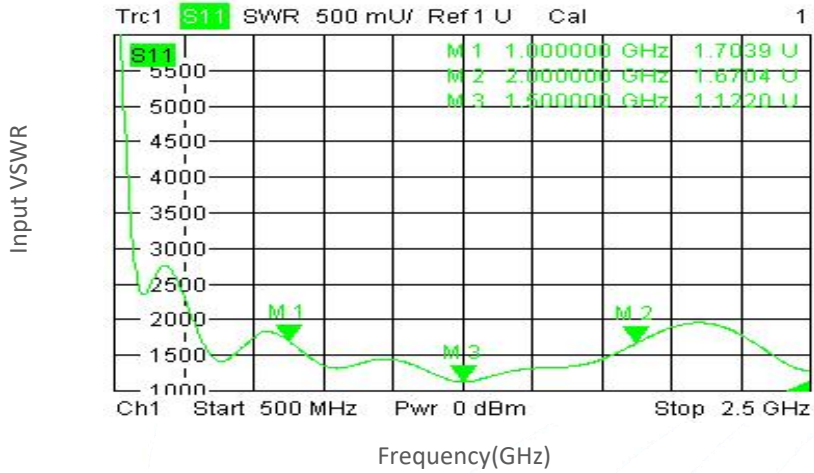

Output VSWR vs Frequency

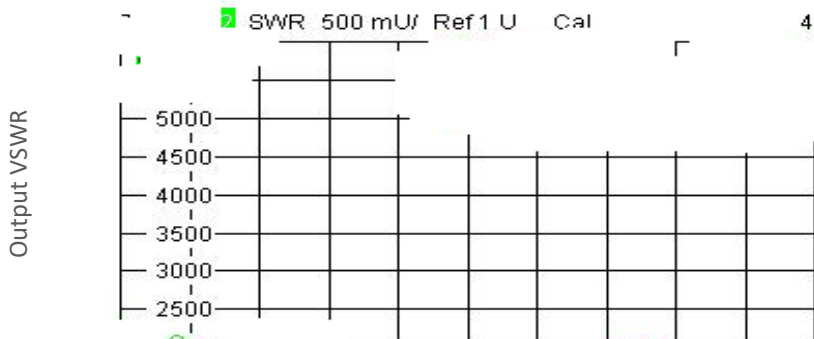

典型曲线 Typical Performance Data:

3.3V:

Phase vs Frequency

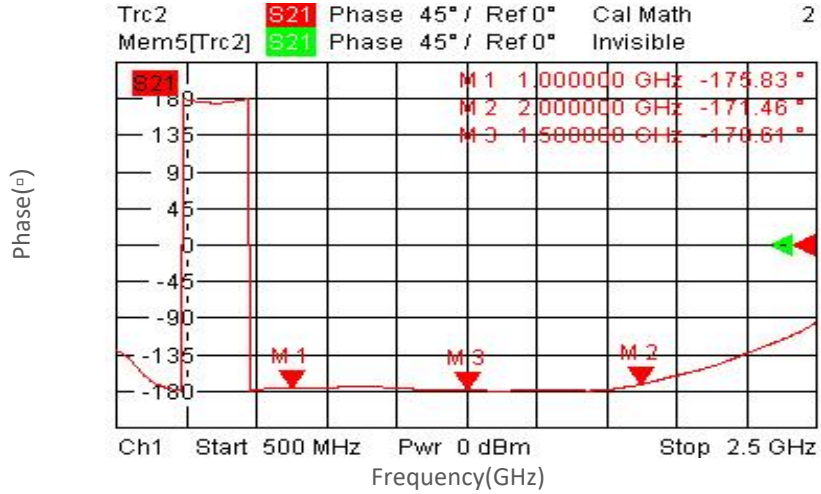

Insertion Loss vs Frequency

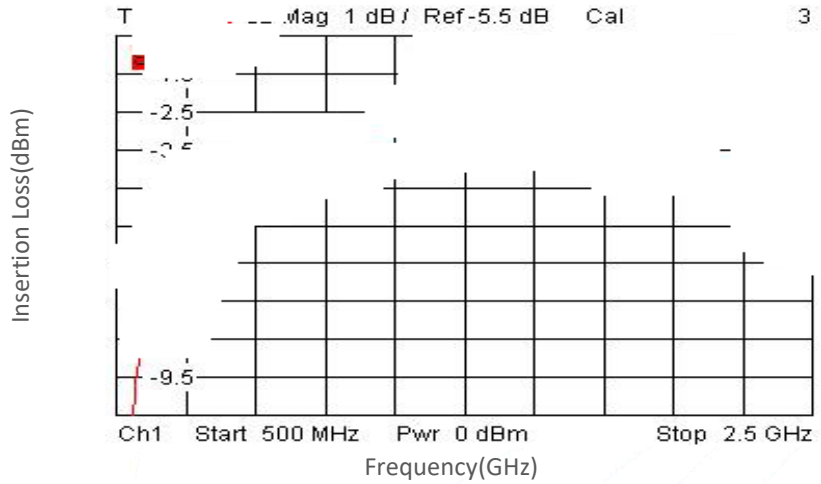

4.4V:

Input VSWR vs Frequency

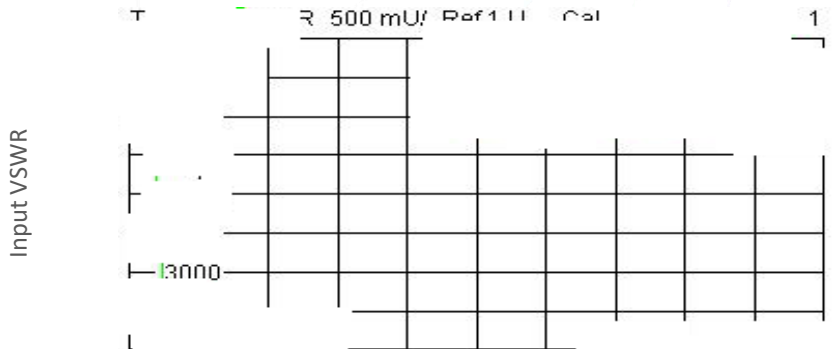

典型曲线 Typical Performance Data:

4.4V:

Output VSWR vs Frequency

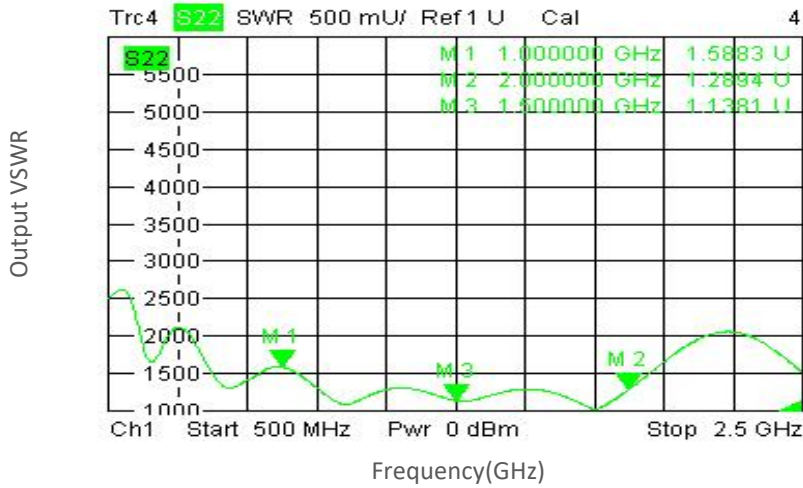

Phase vs Frequency

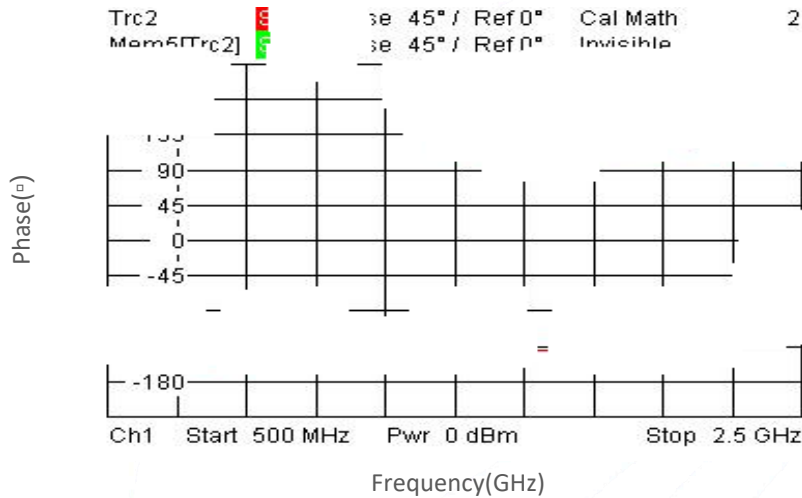

Insertion Loss vs Frequency

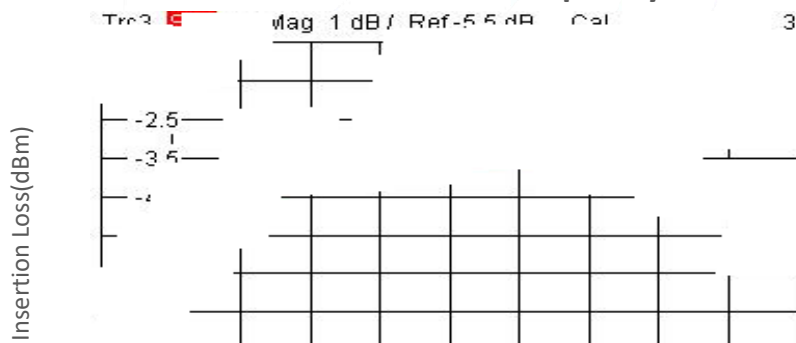

典型曲线 Typical Performance Data:

5.7V:

Input VSWR vs Frequency

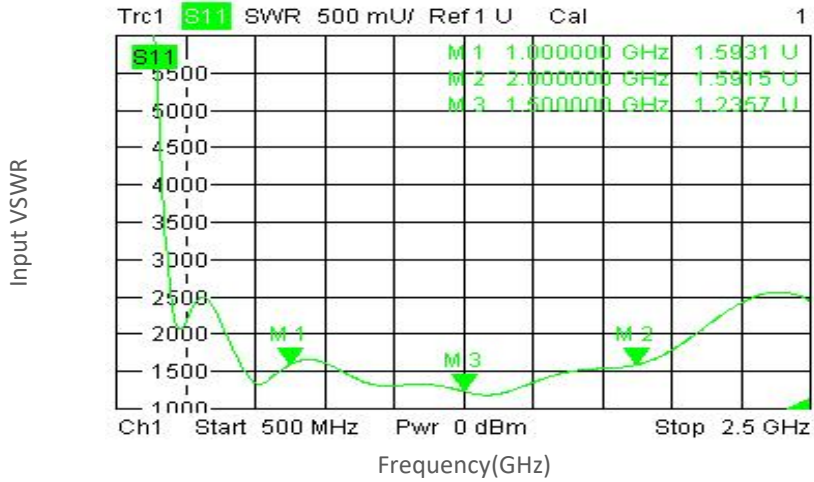

Output VSWR vs Frequency

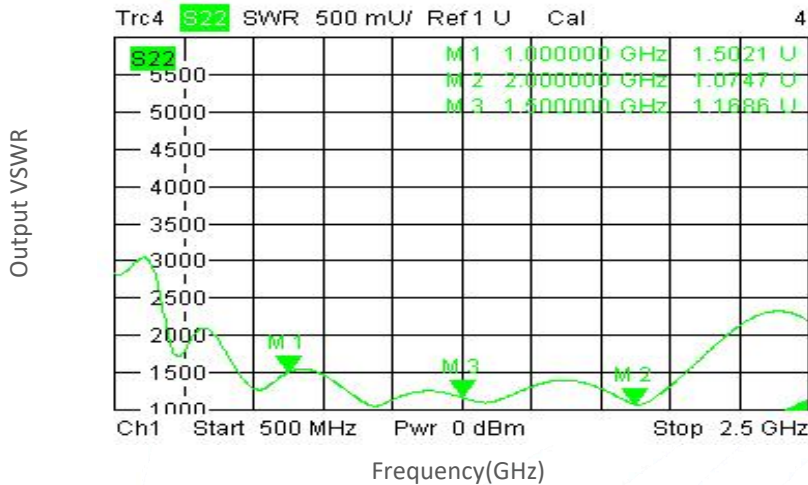

Phase vs Frequency

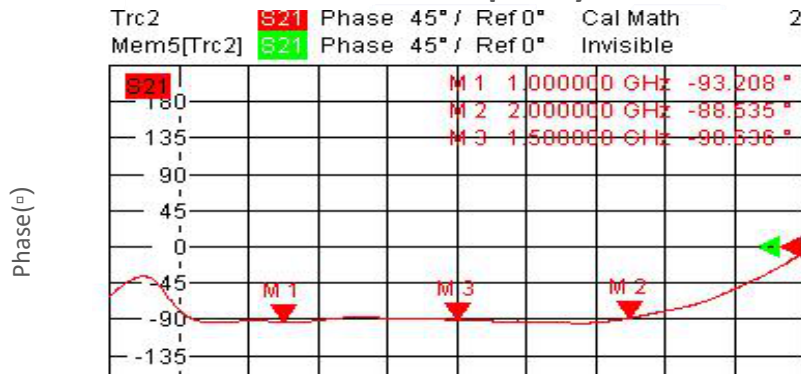

典型曲线 Typical Performance Data:

5.7V:

Insertion Loss vs Frequency

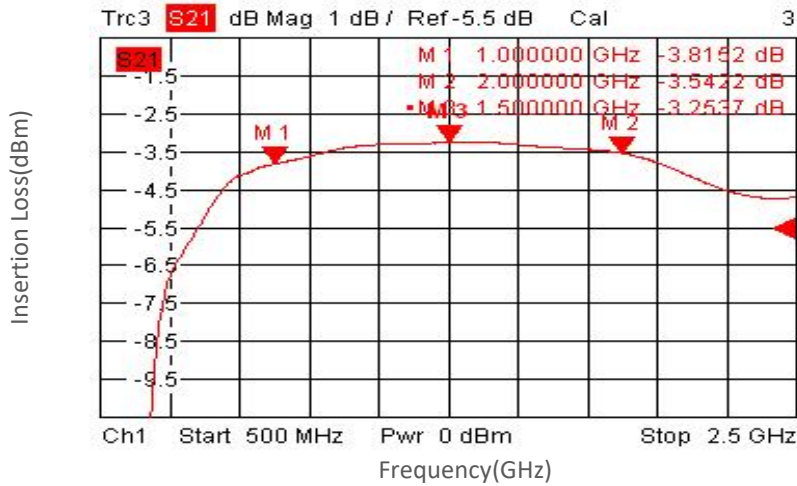

7.2V:

Input VSWR vs Frequency

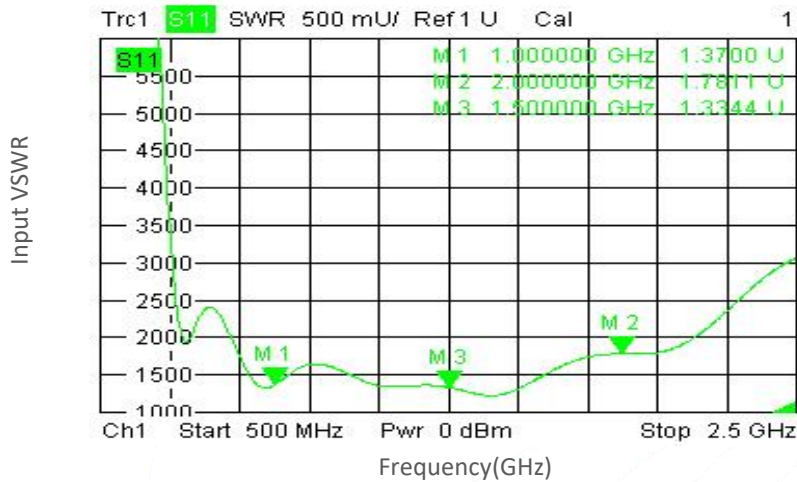

Output VSWR vs Frequency

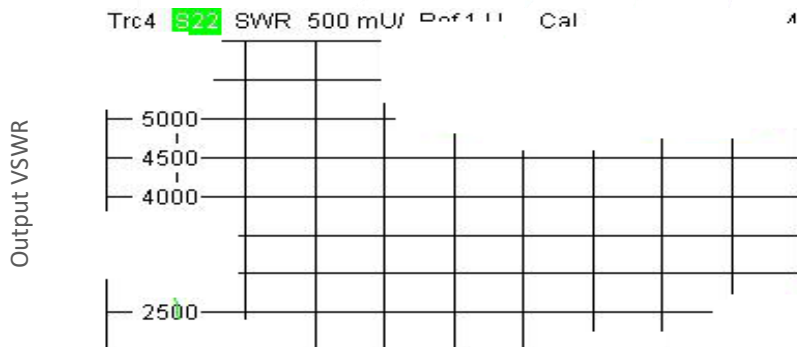

典型曲线 Typical Performance Data:

7.2V:

Phase vs Frequency

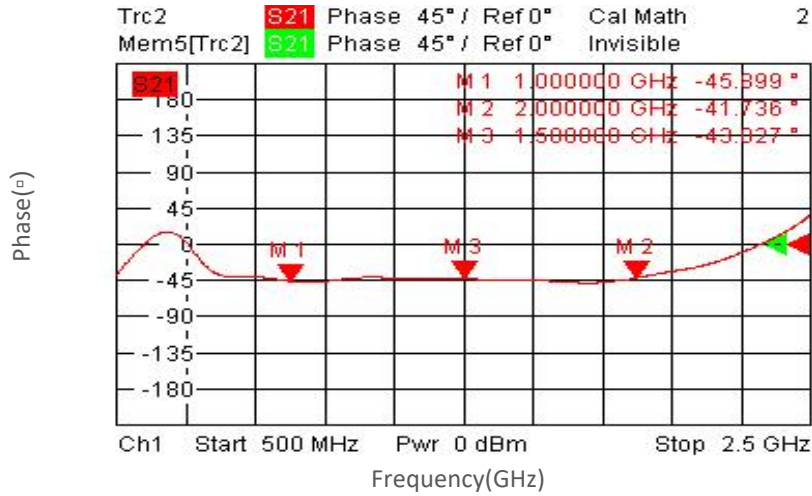

Insertion Loss vs Frequency

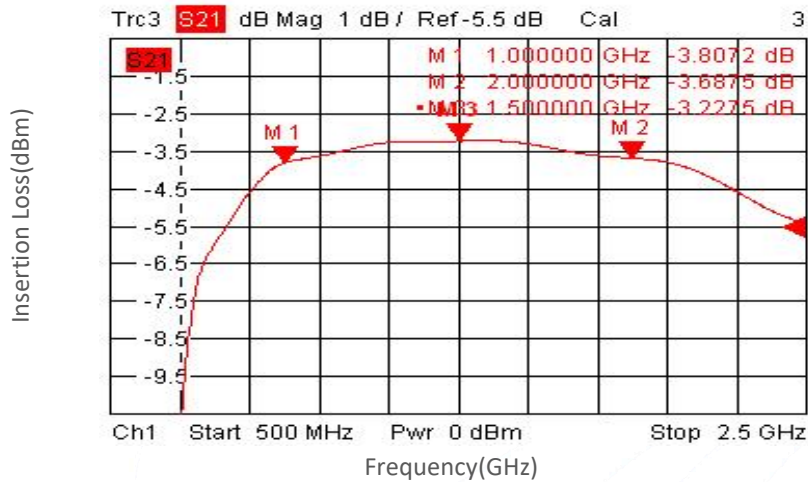

8.8V:

Input VSWR vs Frequency

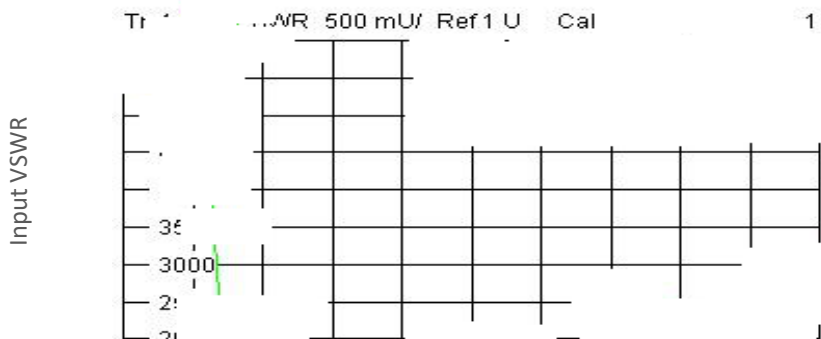

典型曲线 Typical Performance Data:

8.8V:

Output VSWR vs Frequency

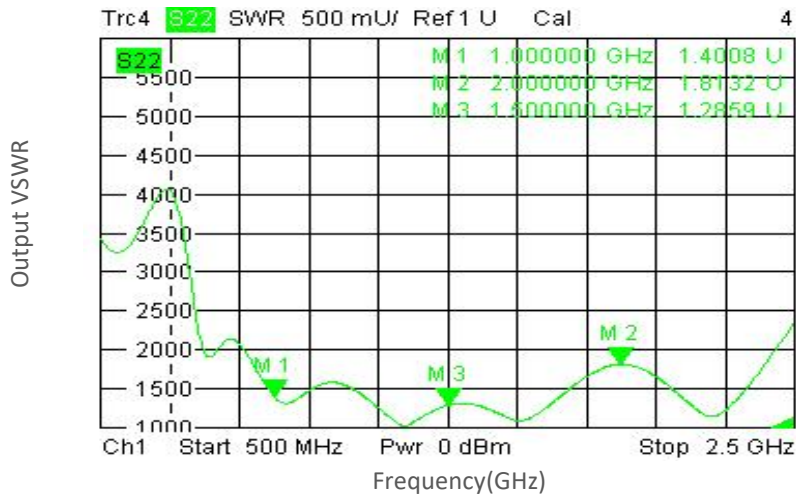

Phase vs Frequency

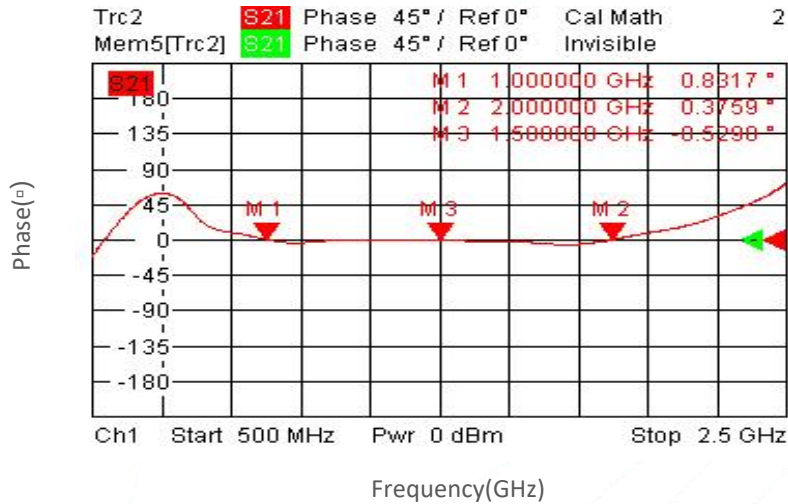

Insertion Loss vs Frequency

