

**Model** TURVP8G18G-360

## Voltage Controlled Phase Shifter 8-18GHz ,SMA Female

**Feature:**

- Frequency Range: 8-18GHz
- High Phase Shift Accuracy
- High Phase Shift Range
- Single Positive Control Voltage

**电气特性 Electrical** :

参数Parameter	Min	Typ	Max	单位Units
频率范围 Frequency range	8-18			GHz
移相范围 Phase Range		360		°
插损 Insertion Loss		7	8	dB
插损温度系数 Insertion Loss Temperature Coefficient		0.003		dB/ °C
三阶交调 Output IM3		40		dBc
输入回损 Input Return Loss		10		dB
输出回损 Output Return Loss		10		dB
控制电压 Control Voltage Range	0	13		V
控制电流 Control Current		5		mA
相位平坦度 Phase Flatness		±15		°
输入功率0.1dB压缩 Input Power for 0.1 dB Compression		20		dBm
阻抗 Impedance	50			Ohms

**机械特性 Mechanical** :

参数Parameter	指标 Value	单位Units
输入/输出接口 Input /Output Connector	SMA Female/SMA Female	
尺寸 Size	20*14*9.5	mm
重量 Weight	/	g

**绝对最大值 Absolute Maximum Ratings:**

参数Parameter	指标 Value
控制电压 Control Voltage Range	+15V

## 外形尺寸 Outline Drawing:

Unit: mm

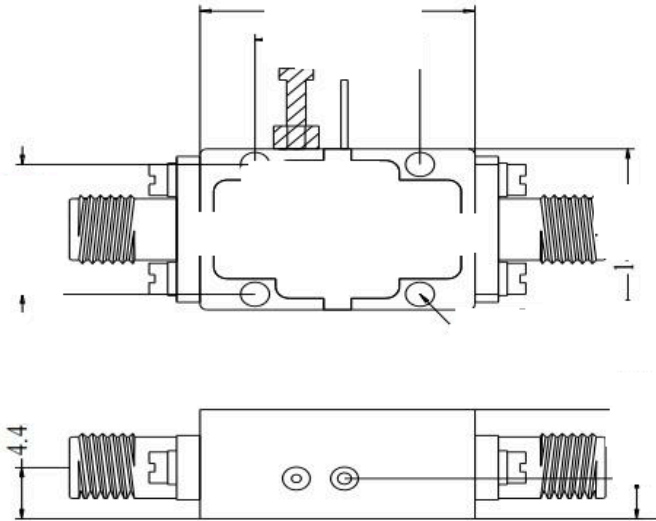

## 温度环境 Environmental Conditions:

参数Parameter	Min	Typ	Max	单位Units
操作温度 Operating Temperature	-45		+85	°C
存储温度 Non-operating Temperature	-55		+125	°C
相对湿度 Relative humidity		95		%
海拔 Altitude	30,000			feet
震动 Shock / Vibration(MIL-STD-810F)	25g rms (15 degree 2KHz) endurance, 1 hour per axis			
冲击 Shock(non operating)	20G for 11msc half sin wave,3 axis both directions			

## 订货信息 Ordering Information:

标准型号 Part Number	描述 Description	版本号Revision
TURVP8G18G-360	Voltage Controlled Phase Shifter ,8-18GHz,SMA Female	Rev.1.1

典型曲线 Typical Performance Data:

0V-0°:

Input VSWR vs Frequency

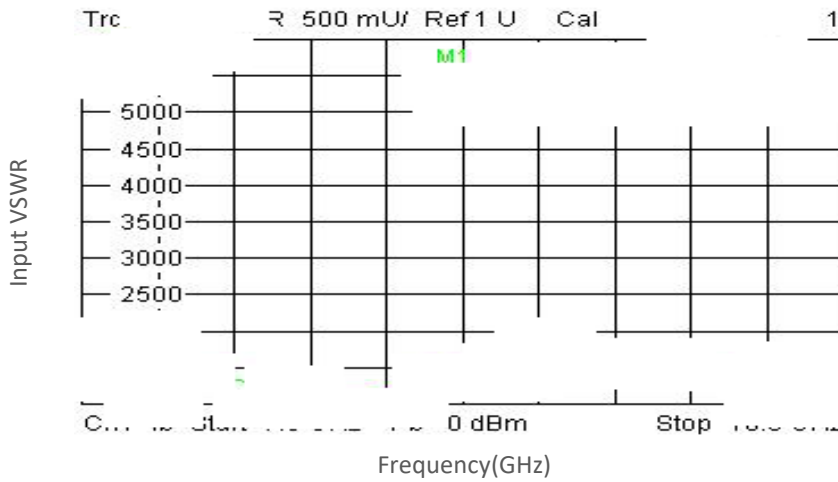

Output VSWR vs Frequency

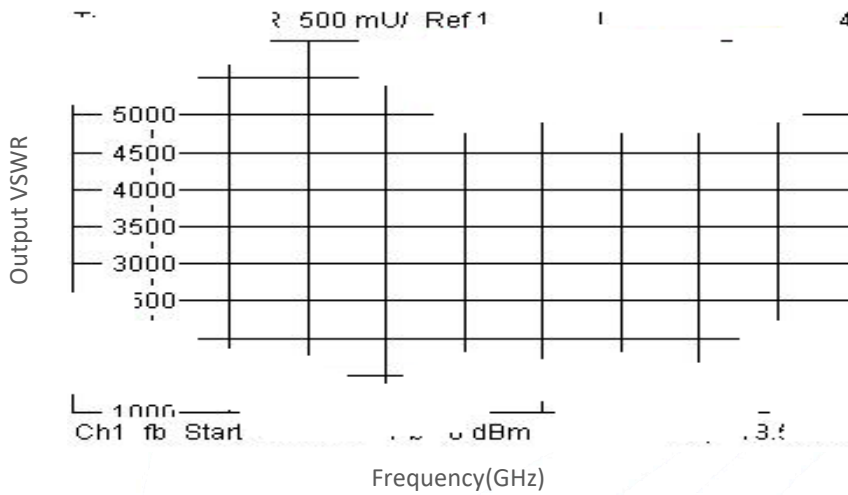

Phase vs Frequency

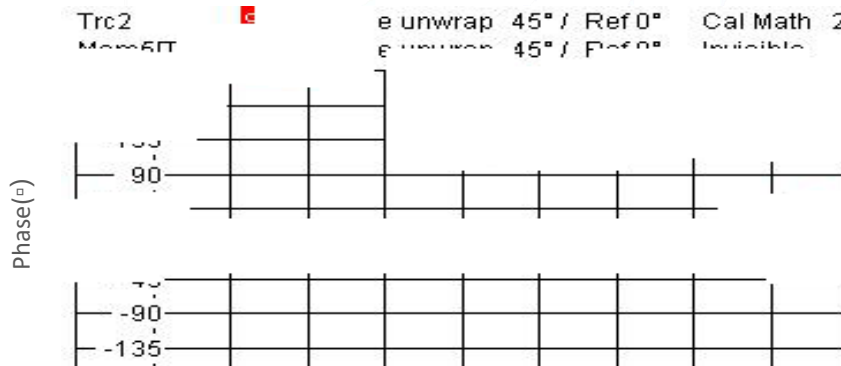

典型曲线 Typical Performance Data:

0V-0°:

Insertion Loss vs Frequency

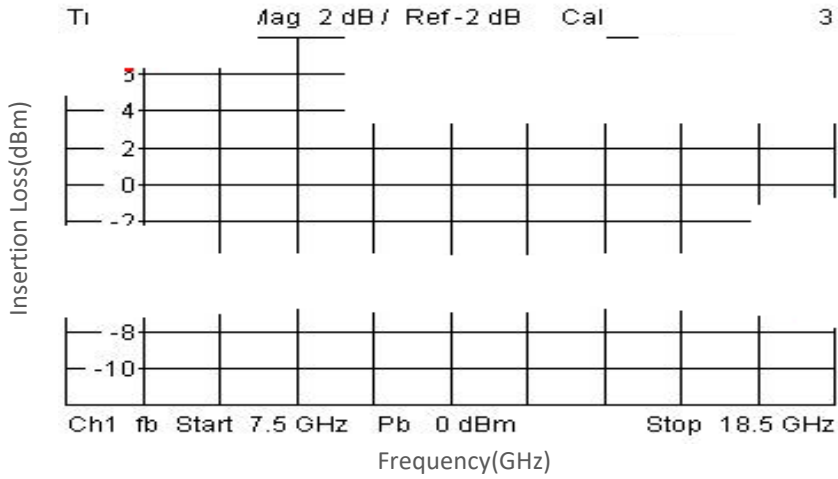

0.12V-12°:

Input VSWR vs Frequency

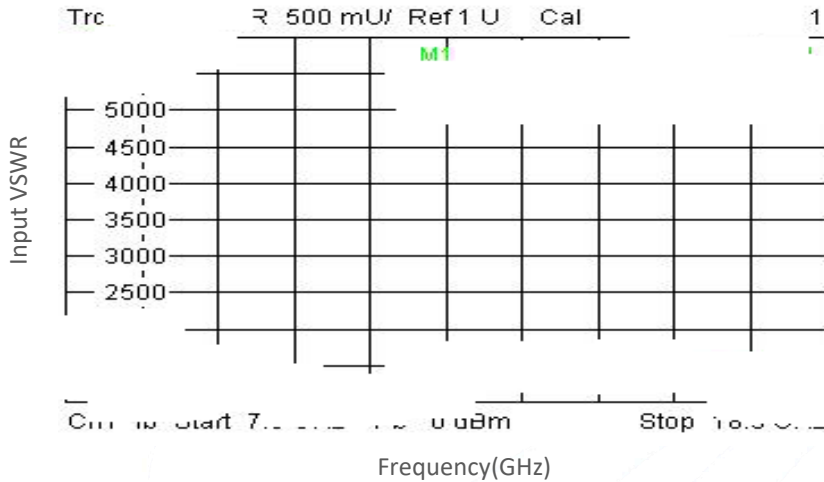

Output VSWR vs Frequency

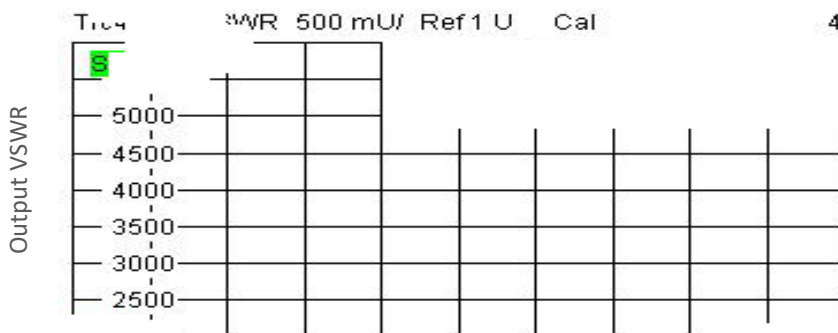

典型曲线 Typical Performance Data:

0.12V-12°:

Phase vs Frequency

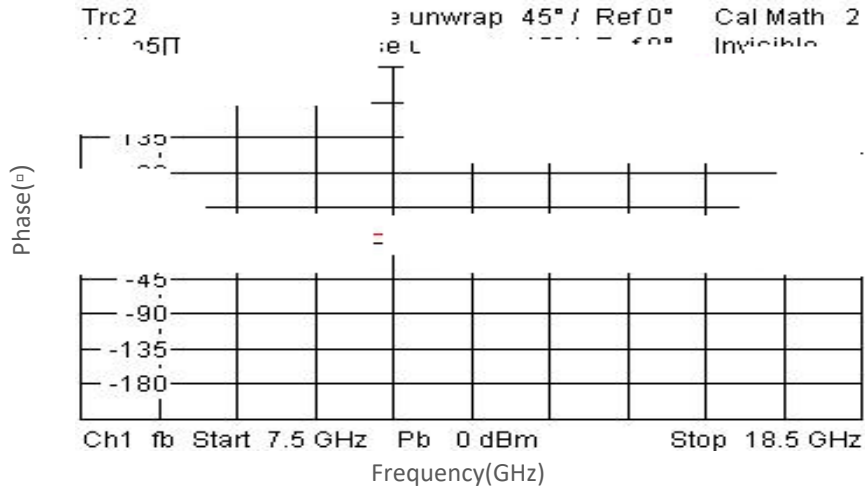

Insertion Loss vs Frequency

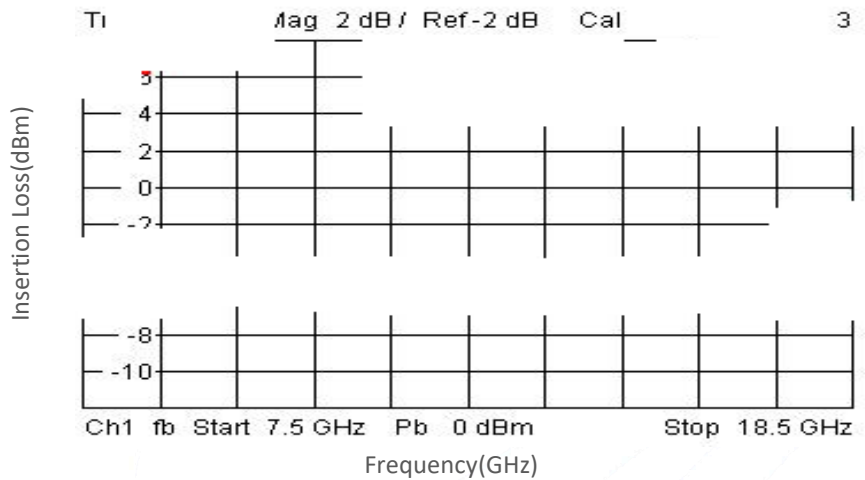

0.25V-24°:

Input VSWR vs Frequency

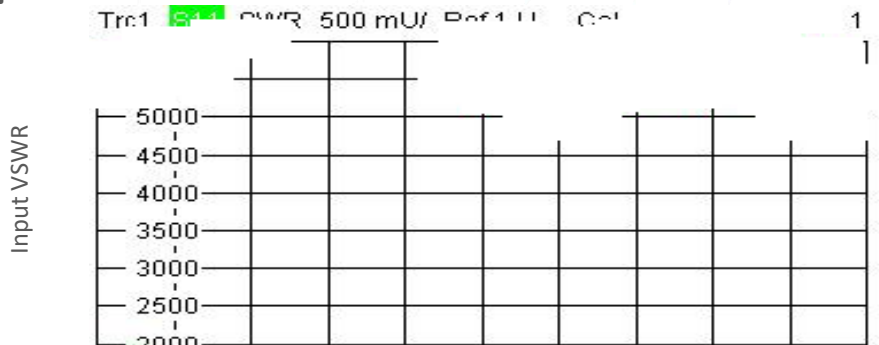

典型曲线 Typical Performance Data:

0.25V-24°:

Output VSWR vs Frequency

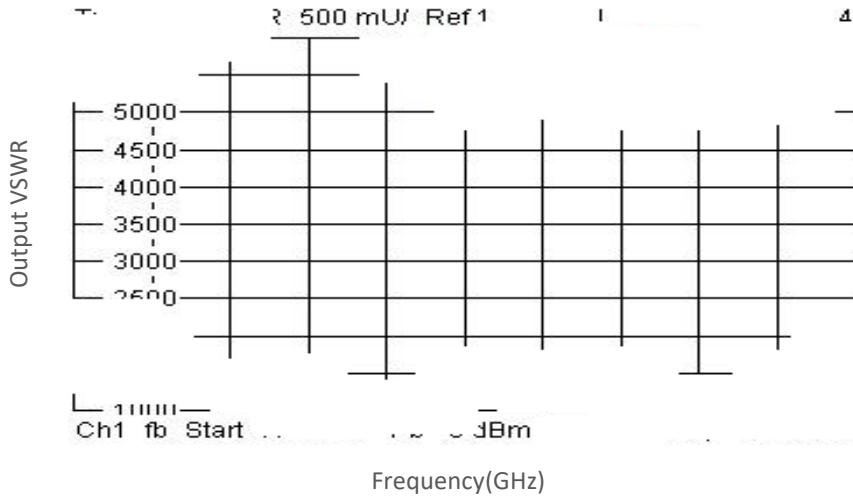

Phase vs Frequency

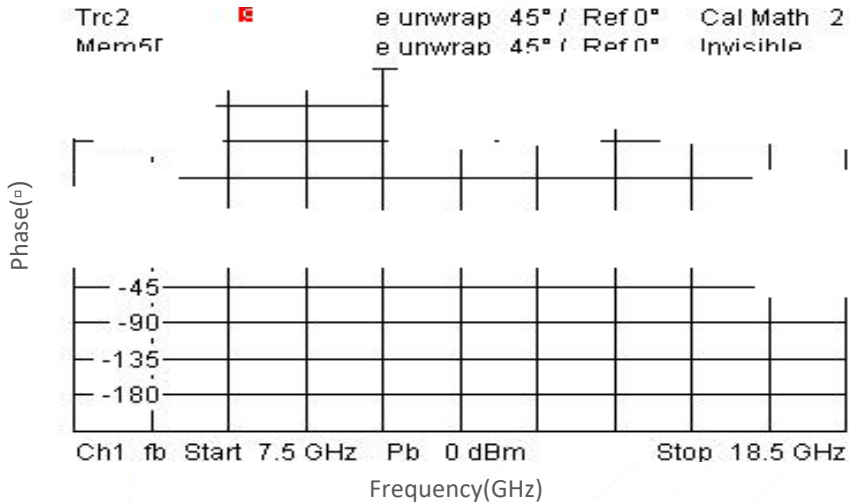

Insertion Loss vs Frequency

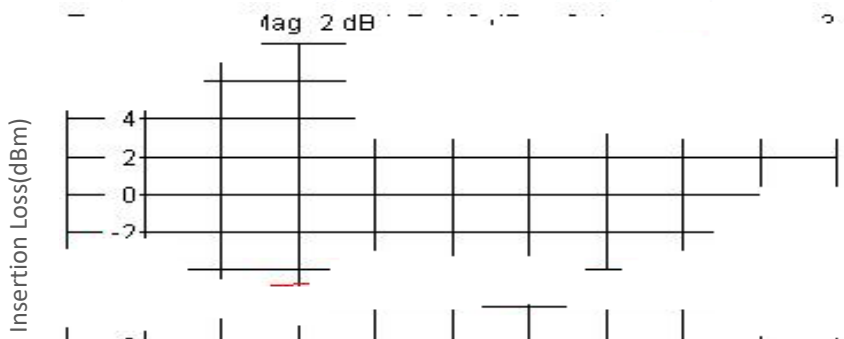

典型曲线 Typical Performance Data:

0.52V-45°:

Input VSWR vs Frequency

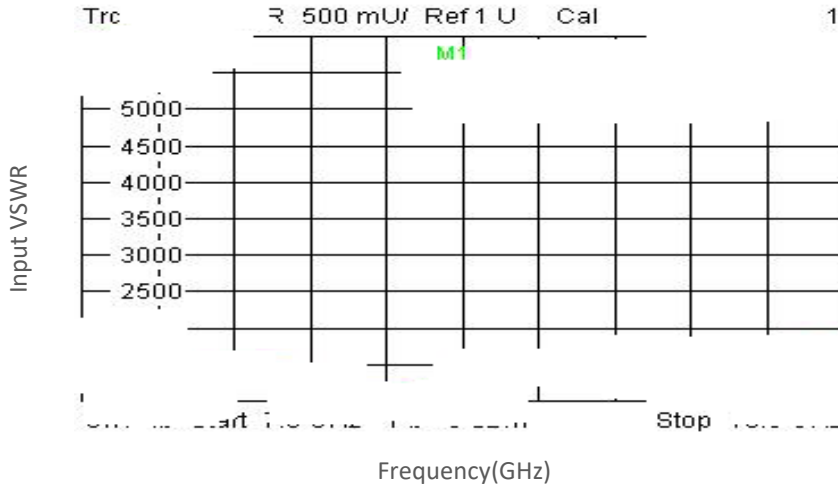

Output VSWR vs Frequency

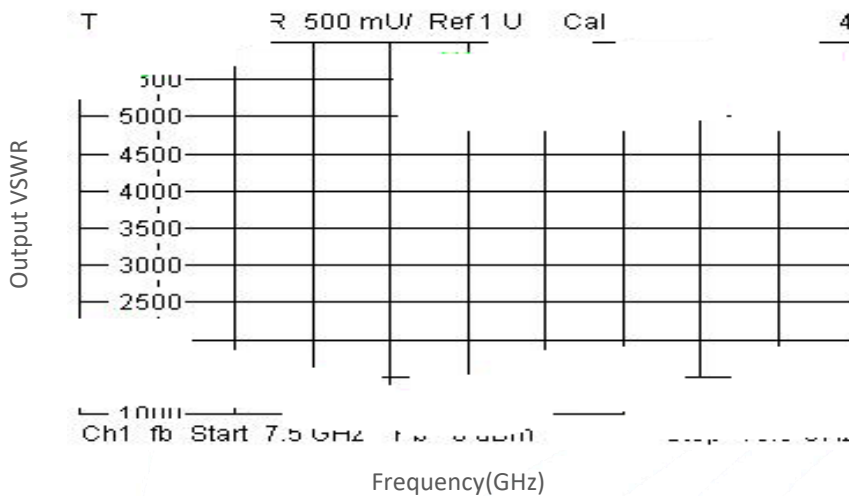

Phase vs Frequency

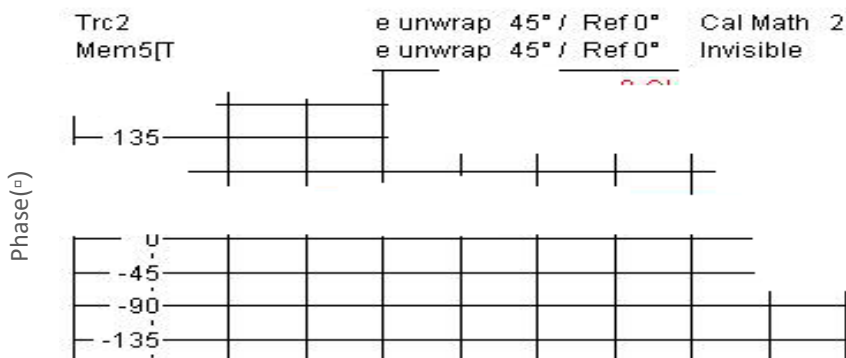

典型曲线 Typical Performance Data:

0.52V-45°:

Insertion Loss vs Frequency

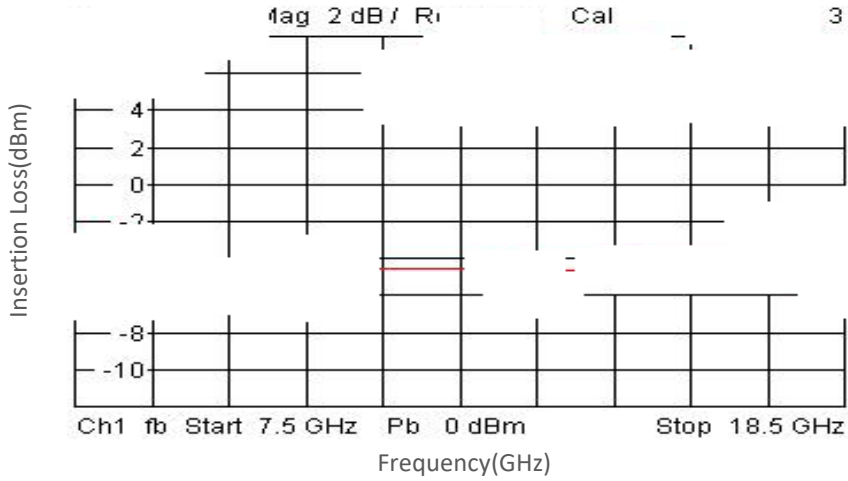

1.26V-90°:

Input VSWR vs Frequency

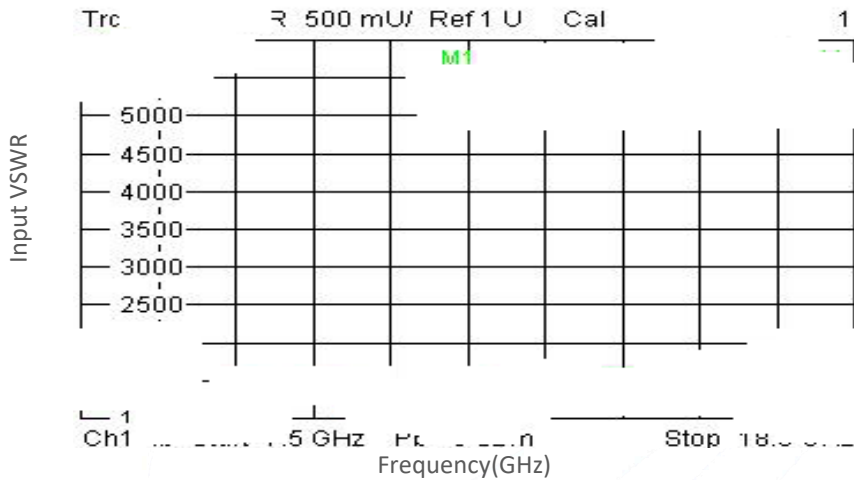

Output VSWR vs Frequency

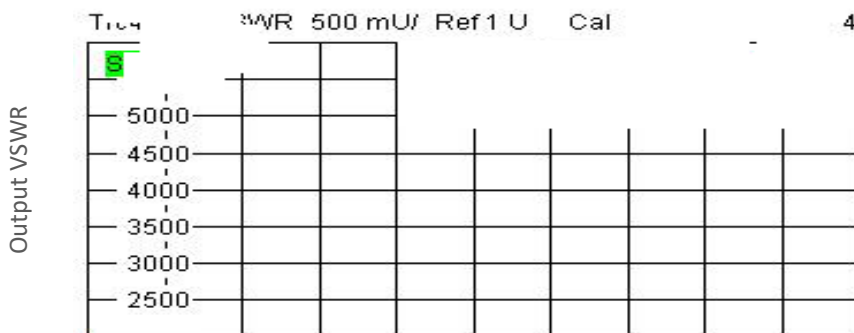

典型曲线 Typical Performance Data:

1.26V-90°:

Phase vs Frequency

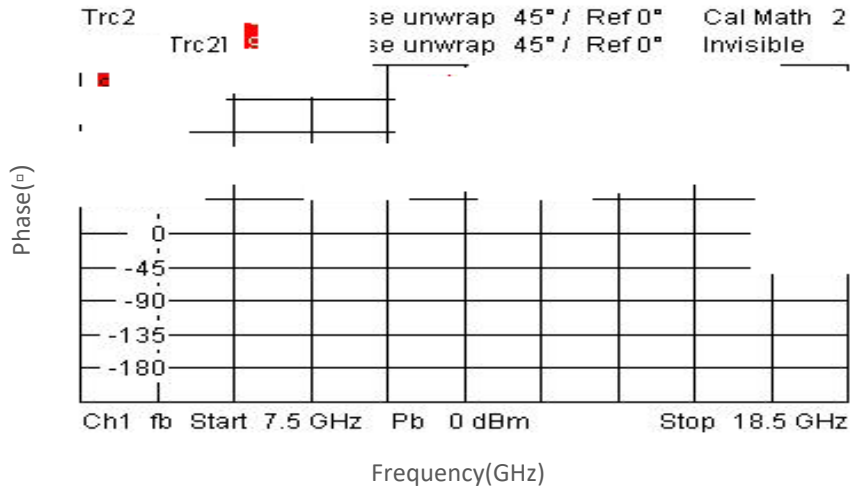

Insertion Loss vs Frequency

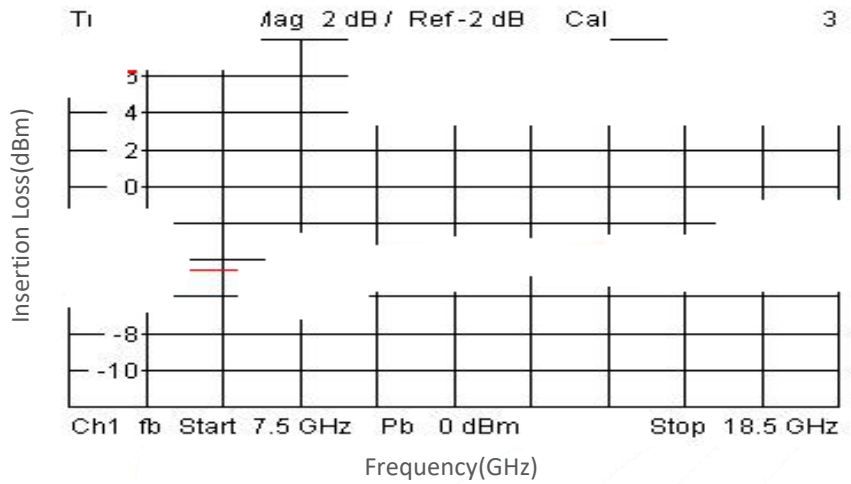

3.29V-180°:

Input VSWR vs Frequency

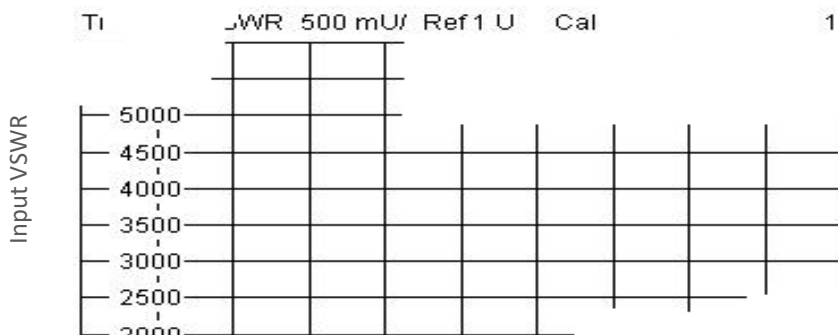

典型曲线 Typical Performance Data:

3.29V-180°:

Output VSWR vs Frequency

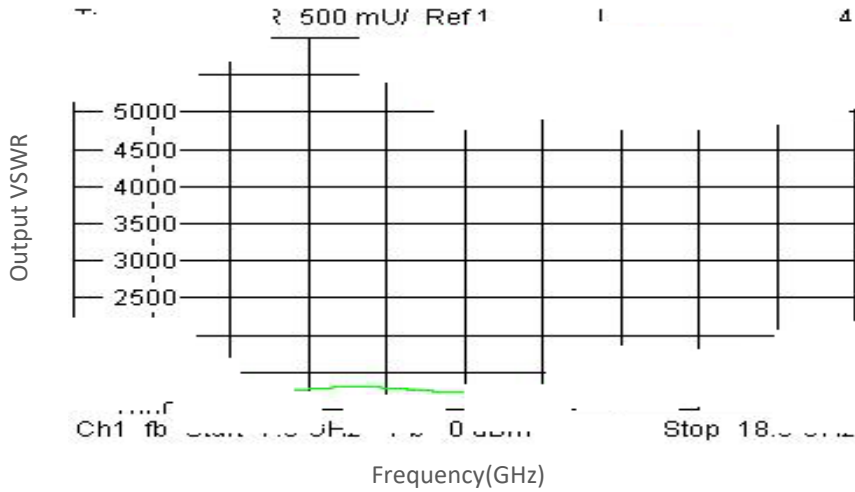

Phase vs Frequency

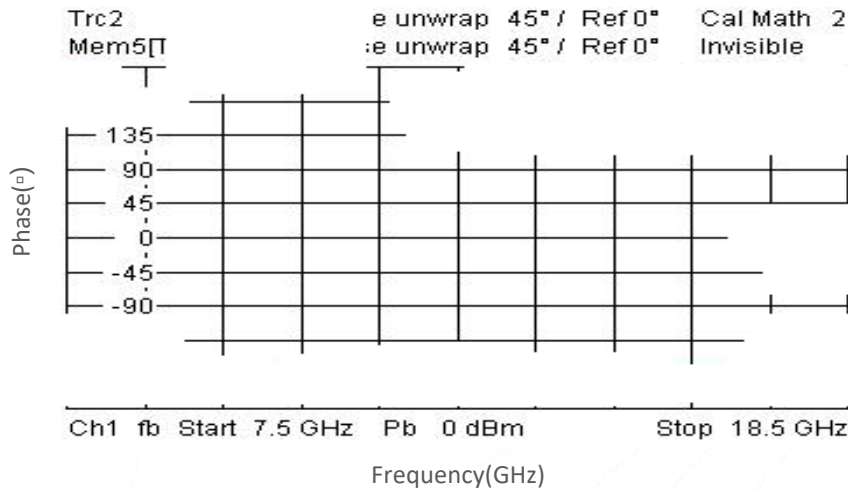

Insertion Loss vs Frequency

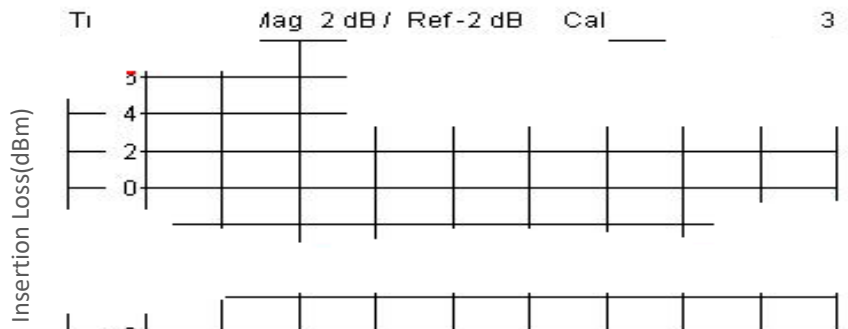

典型曲线 Typical Performance Data:

9.09V-360°:

Input VSWR vs Frequency

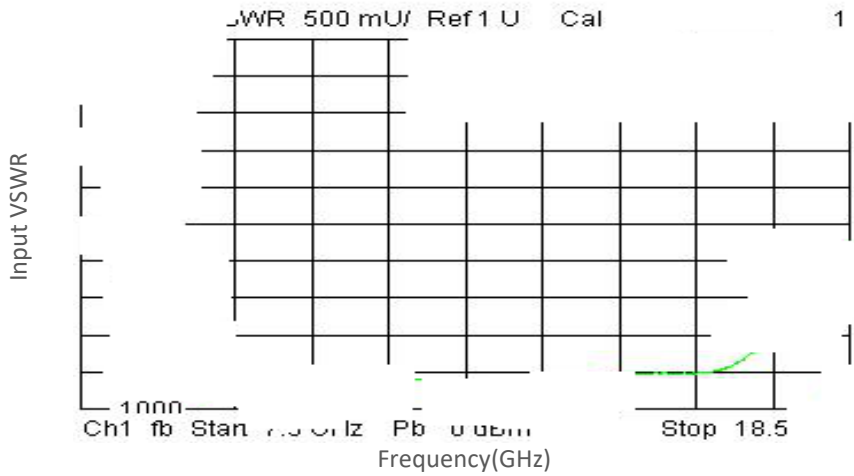

Output VSWR vs Frequency

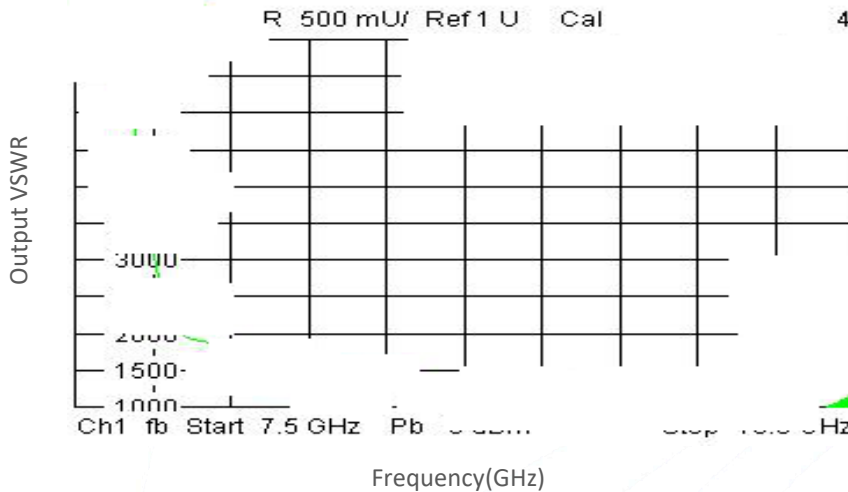

Phase vs Frequency

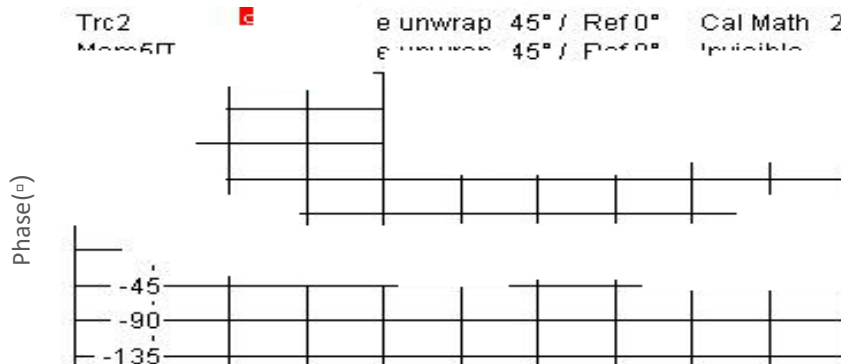

## 典型曲线 Typical Performance Data:

### 9.09V-360°:

### Insertion Loss vs Frequency

